



ECOTEK CANADA PROMOTION TRADE CORPORATION
REGISTERED ADDRESS:
 1188 West Georgia Street, Unit 1440, Vancouver, B.C, Canada, V6E 4A2
 Tel: +1 (778) 928-5580
 Co. Reg. No.: BC0895460
 www.ecotek-canada.vn

ORIGINAL

VALVE REGULATED LEAD ACID BATTERY



Our high quality VRLA batteries are developed with state-of-the-art technology.

- Absorbent Glass Mat (AGM) technology
- Long life
- Small size
- No leakage
- Low self discharge
- No water or electrolyte supplement is required
- Maintenance-free
- They have been widely used in UPS, and other kinds of back-up power.

ECT-UP1226VA3

12V26Ah
MAINTENANCE-FREE

Product



SẢN PHẨM KHÔNG CẦN BẢO DƯỠNG
ĐƯỢC BẢO HIỂM TRÁCH NHIỆM LÊN ĐẾN 2 TRIỆU USD

Dimensions(mm)

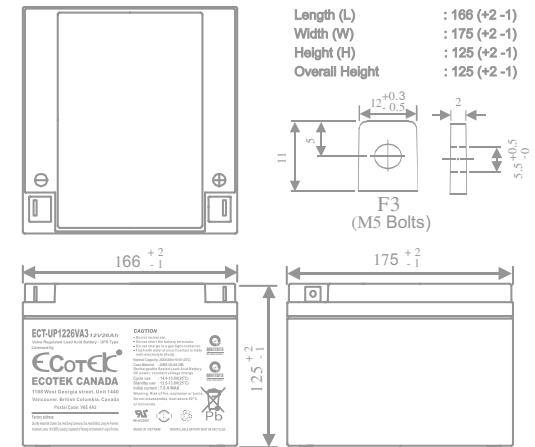

Specifications

Nominal Voltage(V)			12V
Nominal Capacity			
20 hour rate	(1.3A to 10.50V)		26Ah
10 hour rate	(2.47A to 10.50V)		24.7Ah
5 hour rate	(4.42A to 10.20V)		22.1Ah
1C	(26A to 9.60V)		14.73Ah
3C	(78A to 9.60V)		10.4Ah

Weight Approx. **9.3kg**

Internal Resistance (at 1KHz) Approx. **9.5mΩ**

Maximum Discharge Current for 5 seconds: **390A**

Design life **3-5 years**

Case Material **ABS UL94 HB**
 Option: Flammability resistance of (UI94 V-0)

Terminal **F3**

Charging Methods at 25°C(77°F)

Cycle use:	
Charging Voltage	14.4 to 15.0V
Coefficient -5.0mV/°C/cell	
Maximum Charging Current	7.8A
Standby use:	
Float Charging Voltage	13.50 to 13.80V
Coefficient -3.0mV/°C/cell	

Operating Temperature Range

Charge	-15°C(5°F) to 40°C(104°F)
Discharge	-15°C(5°F) to 50°C(122°F)
Storage	-15°C(5°F) to 40°C(104°F)

Charge Retention (shelf life) at 20°C(68°F)

1 month	92%
3 month	90%
6 month	80%

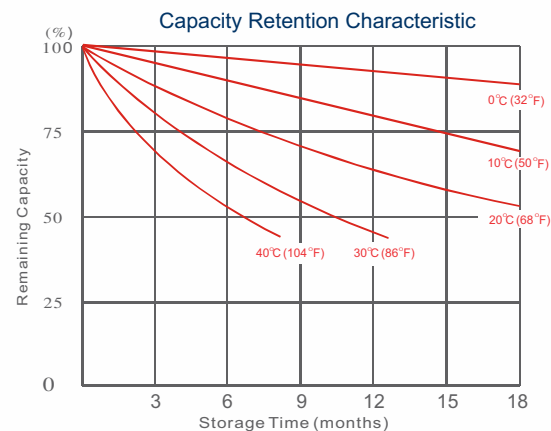
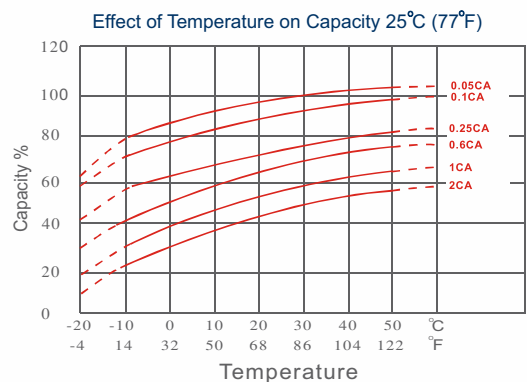
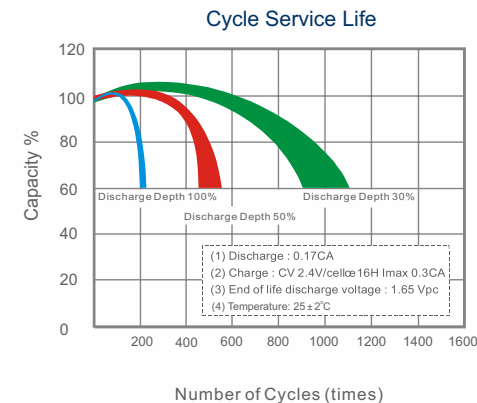
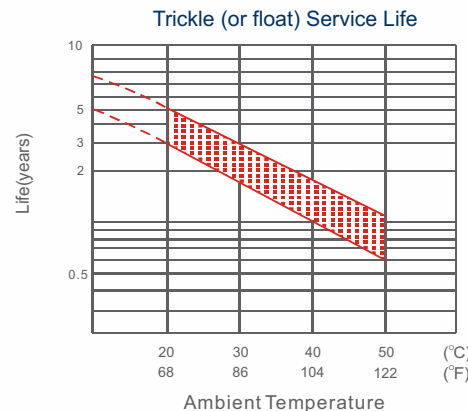
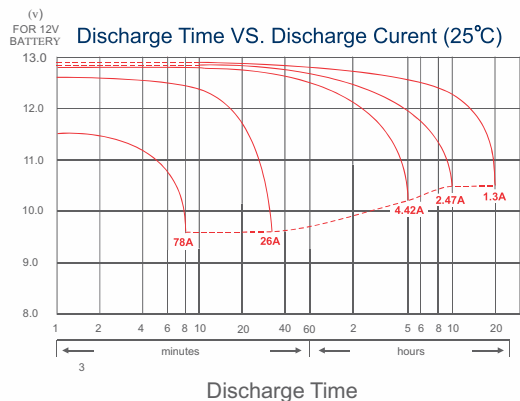

- PERFORMANCE DATA

- Discharge Rates in Watts to Various End Voltages at 25°C (77°F)

Time	End Voltage	1.85V	1.80V	1.75V	1.70V	1.67V	1.65V	1.60V
5	min	147	161	173	185	191	196	208
10	min	108	114	119	125	128	131	135
15	min	78.7	84.0	88.2	92.2	94.2	96.0	99.5
30	min	42.3	45.3	47.2	48.7	49.5	50.3	51.3
60	min	30.2	31.7	32.4	32.8	33.2	33.5	33.8
120	min	19.2	19.8	20.2	20.7	20.8	21.0	21.2
180	min	12.8	13.2	13.4	13.6	13.6	13.7	13.8
240	min	10.3	10.5	10.7	10.8	10.9	10.9	11.0
300	min	8.75	8.90	8.98	9.07	9.10	9.15	9.37
600	min	5.42	5.52	5.58	5.66	5.68	5.72	5.75
1200	min	2.62	2.69	2.74	2.78	2.80	2.82	2.83

- Discharge Rates in Amperes to Various End Voltages at 25°C (77°F)

Time	End Voltage	1.85V	1.80V	1.75V	1.70V	1.67V	1.65V	1.60V
5	min	78.9	92.9	103	109	111	113	115
10	min	55.6	62.1	64.2	68.2	70.4	72.3	75.7
15	min	40.8	46.4	49.8	52.6	54.3	54.9	56.2
30	min	21.4	23.8	25.2	26.5	27.2	27.8	28.8
60	min	15.3	16.1	16.5	16.9	17.1	17.3	17.5
120	min	9.34	9.72	9.87	10.0	10.1	10.2	10.3
180	min	6.45	6.63	6.72	6.83	6.87	6.92	6.99
240	min	5.48	5.61	5.69	5.76	5.79	5.84	5.91
300	min	4.77	4.86	4.93	5.00	5.02	5.05	5.08
600	min	2.55	2.61	2.65	2.69	2.71	2.74	2.77
1200	min	1.29	1.34	1.36	1.38	1.39	1.40	1.43

All data on the spec. sheet is an average value:

The tolerance range : X<6min(+15%~-15%), 6min≤X<10min(+12%~-12%), 10min≤X<60min(+8%~-8%), X≥60min(+5%~-5%)

Contents in this data sheet are subject to change for improvement without prior notice to users. For clarifications and updated information, please contact us.

CÔNG TY NGUYỄN HÀ

AUTHORIZED MASTER DISTRIBUTOR IN VIET NAM
 Address : 3/4 Nguyen Van Thu Street, Dakao Ward, District 1, HCM City
 Tell : (028) 39.111.701 - Fax: (028) 39.111.700
 Email : phanphoi@ecotek-canada.vn - dichvu@ecotek-canada.vn
 Website : www.ecotek-canada.vn Call Center: 1800 1558

Factory has been assessed and certified as meeting the requirements of:

- * ISO 14001:2015 Certified by: SGS United Kingdom
- * OHSAS 18001 :2007 Certified by: SGS Taiwan
- * TL 9000-H:2016(R6)/R5.0 & ISO 9001:2015 Certified by: SGS-CSTC Standards Technical Services, China
- * ISO/IEC 17025 :2005 Certified by: Ministry Of Science and Technology Of Viet Nam

FACTORY ADDRESS:

Duc My Industrial Cluster, Duc Hoa Dong Commune, Duc Hoa District, Long An Province, Viet Nam

INVESTMENT LICENSE No: 1013126870

ISSUED BY: DEPARTMENT OF PLANNING AND INVESTMENT OF LONG AN PROVINCE